

MOLDED CASE CIRCUIT BREAKERS

UL listed MCCBs



Automation Equipment



Contents

UL489 listed Molded Case Circuit Breakers...Series AB

| | |
|----------------------|----|
| Structure | 6 |
| Selection Data | 8 |
| Accessories | 12 |
| Dimensions | 14 |

UL508 listed MMC / IEC MCCBs...Series GB

| | |
|-----------------------------|----|
| Selection Data | 18 |
| Specifications | 20 |
| Characteristic Curves | 22 |
| Dimensions | 23 |

LS MCCB offers more accessories for varied applications and allows easy access to install them, especially for the electrical auxiliaries.



UL489 listed Molded Case Circuit Breakers

Series AB



100AF / 225AF
15 to 100A



225AF
125 to 225A

Compact Design saves the Space

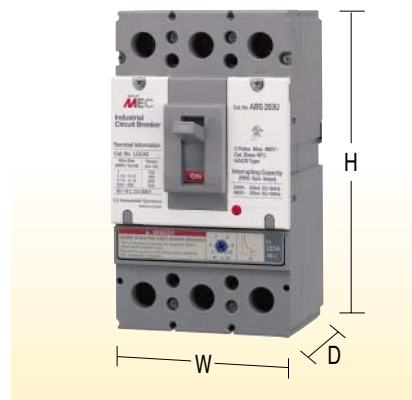

Inches(mm)

| | Width | Height | Depth |
|--------------|---------------|----------------|---------------|
| 100AF | 4.13 (105) | 7.28 (185) | 3.39 (86) |
| 225AF | | | |
| 400AF | 5.51 (140) | 11.02 (280) | 4.33 (110) |
| 600AF | 8.27 (210) | 11.02 (280) | 4.33 (110) |



400AF
250 to 400A



600AF
500 to 600A

Interrupting capacity at 480V AC

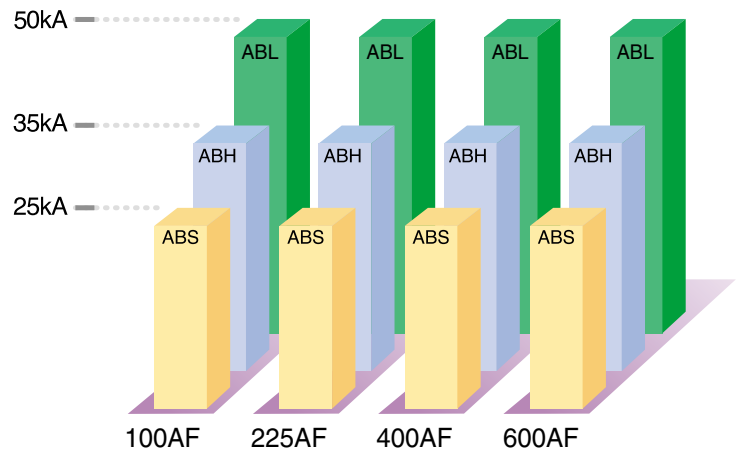

Structure

Series AB

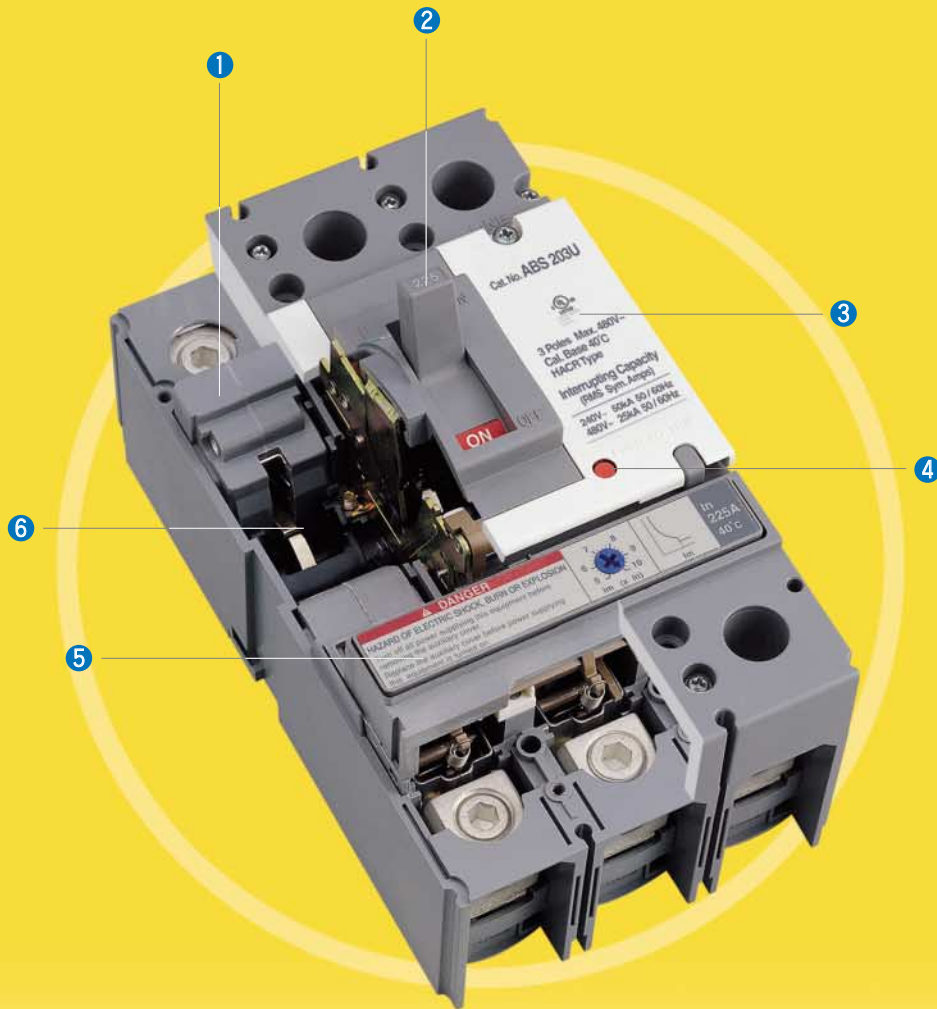

1 Arc Extinguishers

Arc extinguishers dissipate arcs that result when the circuit breaker interrupts current flow.

2 Handle

The handle position clearly indicates the contact status: closed, open or tripped.

The handle indicates "ON" for safety when the contacts are closed.

3 Auxiliary Cover

Auxiliary cover provides convenience when accessories are installed and replaced.

4 Trip Button

Trip button provides a manual means of exercising the mechanism by manually tripping the circuit breaker.

5 Trip Units

The function of the trip unit is to trip the operating mechanism in the event of a prolonged overload or short-circuit current.

To accomplish this, thermal magnetic trip units are provided. Protection is provided by combining a temperature sensitive device with a current sensitive electromagnetic device.

6 Operating Mechanism

Operating mechanism is to provide a means of opening and closing the circuit breaker.

This mechanism is the quick-make, quick-break type and it is constructed so that all poles will make and break simultaneously when operated manually or automatically.

This mechanism is also trip-free.

Catalog Numbering System



Breaker Type

| | |
|-----|------|
| ABN | MCS |
| ABS | 25kA |
| ABH | 35kA |
| ABL | 50kA |

* by UL489 interrupting rating at 480Vac

Ampere Frame

| | |
|----|-------|
| 10 | 100AF |
| 20 | 225AF |
| 40 | 400AF |
| 60 | 600AF |

Poles

| | |
|---|--------|
| 2 | 2Poles |
| 3 | 3Poles |

UL Listed

| | |
|---|--------|
| - | - |
| U | Listed |

Rated Current

| | | | |
|-------|------|-------|------|
| 100AF | 15A | 225AF | 125A |
| | 20A | | 150A |
| | 30A | | 175A |
| | 40A | | 200A |
| | 50A | | 225A |
| 400AF | 60A | 600AF | 250A |
| | 80A | | 300A |
| | 100A | | 350A |
| | | | 400A |
| | | | 500A |
| | | | 600A |

Accessories

| | |
|-----|--------------------|
| AX | Auxiliary switch |
| AL | Alarm switch |
| SHT | Shunt trip |
| UVT | Under voltage trip |
| MI | Mech. Interlock |

* See page 12~13

Note) - Position omitted if not used.

Selection Data

Series AB

Molded Case Circuit Breakers

| Frame Size(AF) | | 100AF | | |
|---|----------|----------------------------------|---------|---------|
| Catalog number | 2-pole | ABS102U | ABH102U | ABL102U |
| | 3-pole | ABS103U | ABH103U | ABL103U |
| Maximum continuous ampere rating at 40°C | | 15, 20, 30, 40, 50, 60, 80, 100A | | |
| UL489 Listed Interrupting ratings (RMS Symmetrical amperes) | 240V AC | 50kA | 65kA | 100kA |
| | 480V AC | 25kA | 35kA | 50kA |
| | 600V AC | - | - | - |
| Type of overcurrent device | | Fixed thermal and magnetic | | |
| Catalog number of wire connector | | LGCA1 | | |
| Dimensions Inches(mm) | Width | 4.13(105) | | |
| | Height | 7.28(185) | | |
| | Depth | 3.39(86) | | |
| Shipping weight | Lbs.(kg) | 4.2(1.9) | | |

- **Applicable Standard**

Molded case circuit breakers are designed and tested in accordance with Underwriters Laboratories, Inc., Standard UL489.(UL file No. : E231289)

- **Wire connectors**

Circuit breakers are supplied with line & load side connectors.

- **Calibration**

Circuit breakers are calibrated for 40°C maximum ambient application. Unless marked otherwise, circuit breakers are 80% duty rated.

- **HACR rated**

Circuit breakers are HACR rated.

- **Wire**

Circuit breakers are to be connected with 60 or 75°C wire for circuit breakers having a rated current of 125 amperes or less. Circuit breakers having a rated current greater than 125 amperes shall only be cabled with 75°C cable.



| 225AF | | | 400AF | | | 600AF | | |
|---------------------------------------|---------|---------|----------------------------|---------|---------|----------------------------|---------|---------|
| ABS202U | ABH202U | ABL202U | ABS402U | ABH402U | ABL402U | ABS602U | ABH602U | ABL602U |
| ABS203U | ABH203U | ABL203U | ABS403U | ABH403U | ABL403U | ABS603U | ABH603U | ABL603U |
| 125, 150, 175, 200, 225A | | | 250, 300, 350, 400A | | | 500, 600A | | |
| 50kA | 65kA | 100kA | 50kA | 65kA | 100kA | 50kA | 65kA | 100kA |
| 25kA | 35kA | 50kA | 25kA | 35kA | 50kA | 25kA | 35kA | 50kA |
| - | - | - | 14kA | 18kA | 18kA | 14kA | 18kA | 22kA |
| Fixed thermal and adjustable magnetic | | | Fixed thermal and magnetic | | | Fixed thermal and magnetic | | |
| LGCA2 | | | LGCA4 | | | LGCA6 | | |
| 4.13(105) | | | 5.51(140) | | | 8.27(210) | | |
| 7.28(185) | | | 11.02(280) | | | 11.02(280) | | |
| 3.39(86) | | | 4.33(110) | | | 4.33(110) | | |
| 4.4(2.0) | | | 12.3(5.6) | | | 19.4(8.8) | | |

● Magnetic trip settings

| Frame Size(AF) | Ampere rating(In) | Magnetic trip settings |
|----------------|-------------------|-------------------------------|
| 100AF | 15A | 500A |
| | 20A | 500A |
| | 30A | 500A |
| | 40A | 500A |
| | 50A | 500A |
| | 60A | 600A |
| | 80A | 800A |
| 225AF | 100A | 1000A |
| | 125A | 5,6,7,8,9,10 x In(Adjustable) |
| | 150A | 5,6,7,8,9,10 x In(Adjustable) |
| | 175A | 5,6,7,8,9,10 x In(Adjustable) |
| | 200A | 5,6,7,8,9,10 x In(Adjustable) |
| 400AF | 225A | 5,6,7,8,9,10 x In(Adjustable) |
| | 250A | 2500A |
| | 300A | 3000A |
| | 350A | 3500A |
| 600AF | 400A | 4000A |
| | 500A | 5000A |
| | 600A | 6000A |

* UL magnetic trip setting tolerances are -20% and +30% from the nominal values shown.

Selection Data

Series AB

Molded Case Switches

| Frame Size(AF) | 100AF | 225AF | 400AF | 600AF |
|---|----------------|---------|---------|---------|
| Catalog number | ABN103U | ABN203U | ABN403U | ABN603U |
| Poles | 3 | 3 | 3 | 3 |
| Maximum voltage ratings | 480V AC | 480V AC | 600V AC | 600V AC |
| Switch ampere ratings | 30,60,100A | 225A | 400A | 600A |
| Short circuit withstand ratings | 240V AC | 100kA | 100kA | 100kA |
| | 480V AC | 50kA | 50kA | 50kA |
| | 600V AC | - | - | 18kA |
| Catalog number of wire connector | LGCA1 | LGCA2 | LGCA4 | LGCA6 |
| Dimensions | Same as MCCB | | | |
| Shipping weight | Same as MCCB | | | |



- Molded Case Switches are listed in accordance with Underwriters Laboratories, Inc., Standard UL489. (UL file No. : E223516)
- Molded Case Switches are calibrated to protect only the Molded Case Switch itself, when it is subjected to high fault currents.
- Molded Case Switches open instantaneously at a factory preset magnetic trip point and provide no overload or low level fault protection.
- The short circuit withstand rating is the fault current at rated voltage that the molded case switch will withstand without damage when protected by a circuit breaker with an equal continuous current rating.
- Molded case switches are used as compact switches in applications requiring high current switching capabilities.
- All molded case switches will accept the same lugs and accessories as equivalent circuit breakers.
- Molded case switches open when the handle is switched to the OFF position or in response to auxiliary tripping device such as a shunt trip.

Trip Point of MCS

| Frame Size(AF) | Ampere rating | Trip point |
|----------------|---------------|------------|
| 100AF | 30A | 500A |
| | 60A | 600A |
| | 100A | 1000A |
| 225AF | 225A | 2250A |
| 400AF | 400A | 4000A |
| 600AF | 600A | 6000A |

* UL magnetic trip setting tolerances are -20% and +30% from the nominal values shown.

Lug information

| Catalog No. | Shape | Terminal Material | Wire range | | Tightening Torque lb-in(kgf.cm) | Binding screw | |
|--------------|---|-------------------|------------|----------------------|------------------------------------|---------------|-------------------|
| | | | AWG,kcmil | Number of conductors | | Head Style | Size (inches) |
| LGCA1 |  | Aluminum alloy | 14 ~ 8 | 1 | 60(69) | Slotted Head | 7/16-20 UNF 2A |
| | | | 6 ~ 1/0 | 1 | 80(92) | | |
| LGCA2 |  | Aluminum alloy | 1 | 1 | 150(173) | Hex. Head | 9/16-18 UNF 2A |
| | | | 1/0 ~ 2/0 | 1 | 180(207) | | |
| | | | 3/0 ~ 4/0 | 1 | 250(288) | | |
| | | | 250 ~ 300 | 1 | 325(374) | | |
| LGCA4 |  | Aluminum alloy | 250 ~ 400 | 1 | 325(374) | Hex. Head | 1-12 UNF 2A |
| | | | 500 | 1 | 375(432) | | |
| | | | 3/0 | 2 | 250(288) | | |
| LGCA6 |  | Aluminum alloy | 250 ~ 400 | 2 | 325(374) | Hex. Head | 5/8-18 UNF 2A |
| | | | 500 | 2 | 375(432) | | |

- Lug terminals are listed in accordance with Underwriters Laboratories, Inc., Standard UL486A.
- Lug terminals are suitable for compact wires that CSA Standard (C22.2 No.65) require.
- Wire connectors intended for use with copper conductors only.
- Lug terminals are suitable for 60/75°C wire.



ISO 9001
ISO 14001



Accessories

Series AB

Electrical auxiliaries

- Compartments are accessible from the front by opening auxiliary cover.
- Not necessary to take off the breaker cover.

● 100, 225AF breakers

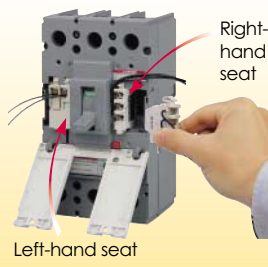

● 400, 600AF breakers

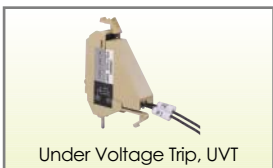
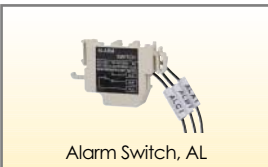
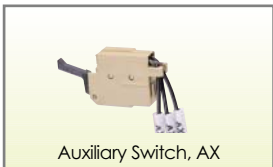
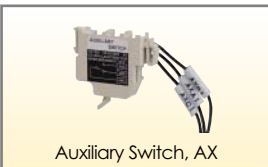
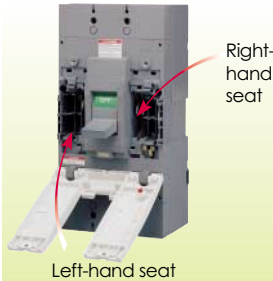

Auxiliary Switch, AX

Signals the status of the breaker - opening or closing
Consists of one changeover switch per unit

Alarm Switch, AL

Signals when a breaker is tripped
Consists of one changeover switch

Ratings of the AX & AL

| Operational voltage(V) | AC | | Operational voltage(V) | DC | |
|------------------------|---------------------------|----------------|------------------------|---------------------------|----------------|
| | Max. switching current(A) | | | Max. switching current(A) | |
| | Resistive load | Inductive load | | Resistive load | Inductive load |
| 125 | 5 | 3 | 30 | 4 | 3 |
| 250 | 3 | 2 | 125 | 0.4 | 0.4 |
| | | | 250 | 0.2 | 0.2 |

Shunt trip, SHT

Trips a breaker remotely

| | 100AF | 225AF | 400AF | 600AF |
|----------------------------|--|-------|------------------------|----------------------|
| AC/DC common | 12/24/48/60/250V | | 24~48V | AC200~240/DC200~220V |
| AC | 100~125/200~240 380~450/440~480 500~550V | | 380~460/480~550V | AC100~125/DC100~110V |
| DC | 100~110/125/200~220 240/250V | | | - |
| Operational voltage | 75~110% of rated volts | | 75~110% of rated volts | |

Under voltage trip, UVT

Trips a breaker when control voltage disappears or falls below the set value

| | 100AF | 225AF | 400AF | 600AF |
|-------------------------------|------------------------|-------|-------|-------|
| AC/DC common | 24/48/100~110/200~220V | | | |
| AC | 380~440V, 440~480V | | | |
| Operational voltage | 35~70% of rated volts | | | |
| Re-close voltage of CB | 85~110% of rated volts | | | |

Maximum possibilities for auxiliaries

- 100, 225AF breakers

Left-hand seat



Right-hand seat

Left-hand seat

Option of connecting 2AX or AX+AL or SHT or UVT

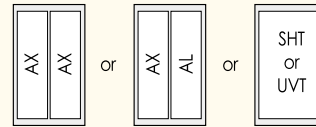

Right-hand seat

Option of connecting 2AX or AL+AX

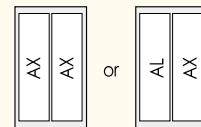

- 400, 600AF breakers

Left-hand seat



Right-hand seat

Left-hand seat

Option of connecting 2AX, 2AL and SHT or UVT

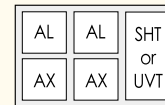

Right-hand seat

Option of connecting 2AX, 2AL and SHT or UVT

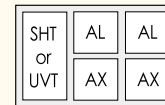

External accessories

Mechanical Interlock

These are applied between two breakers to prevent mechanically closing together.

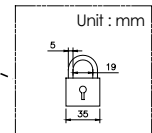
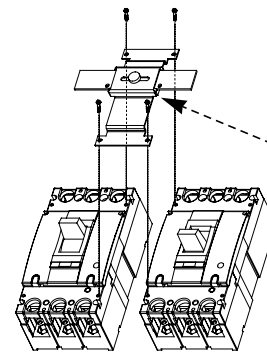
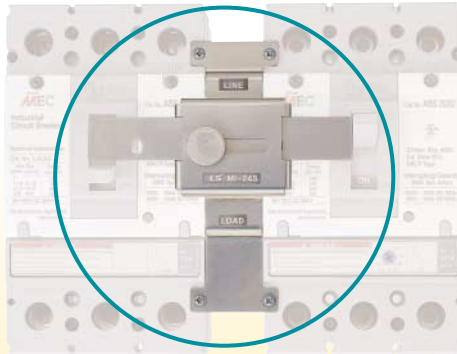

Applicable lock if necessary (not supplied)

Other accessory



Insulation barrier

* UL file No. of accessories : E223241

| Catalog No. | Applied MCCB |
|---------------|---|
| MI-23S | 2 & 3 poles 100AF(15 to 100A) 2 & 3 poles 225AF(125 to 225A) |
| MI-43S | 2 & 3 poles 400AF(250 to 400A) |
| MI-83S | 2 & 3 poles 600AF(500 to 600A) |

Dimensions

Series AB

ABS/ABH/ABL 102U, 103U, ABN 103U

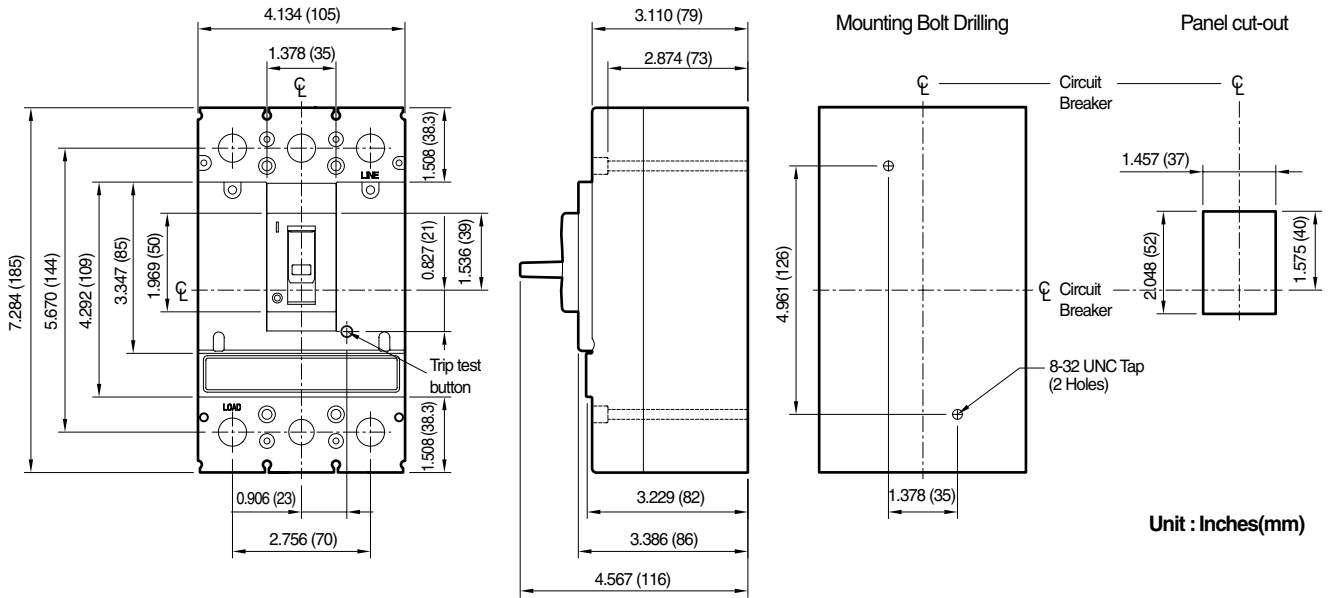

ABS/ABH/ABL 202U, 203U, ABN 203U

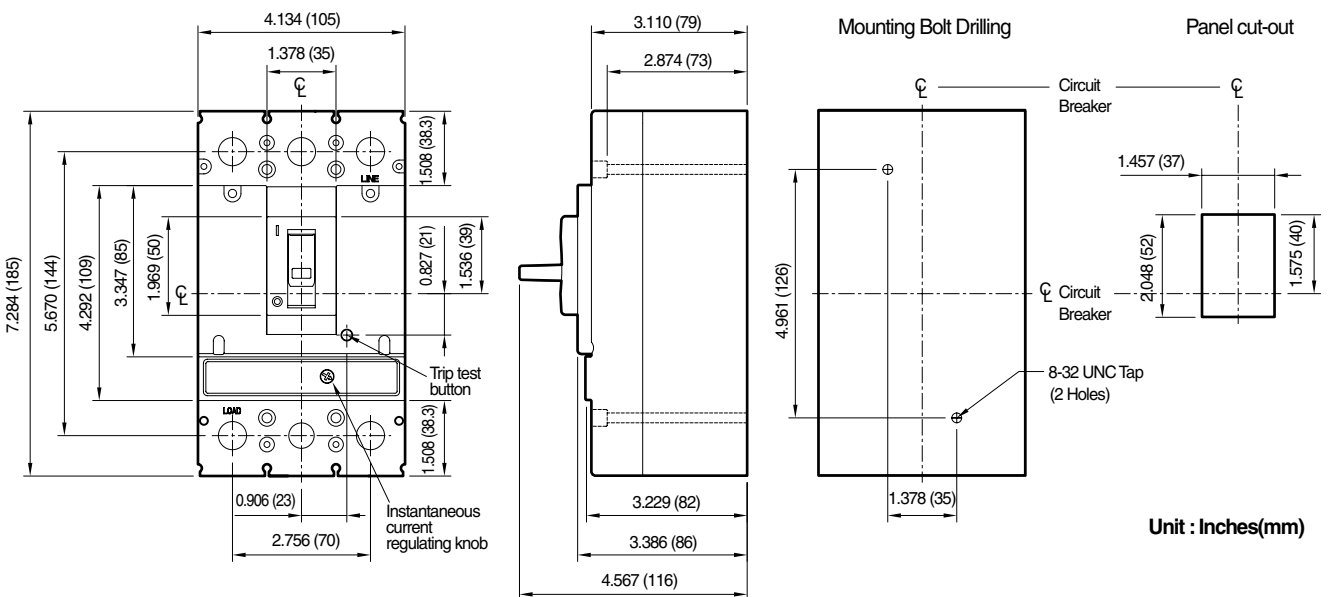

ABS/ABH/ABL 402U, 403U, ABN 403U

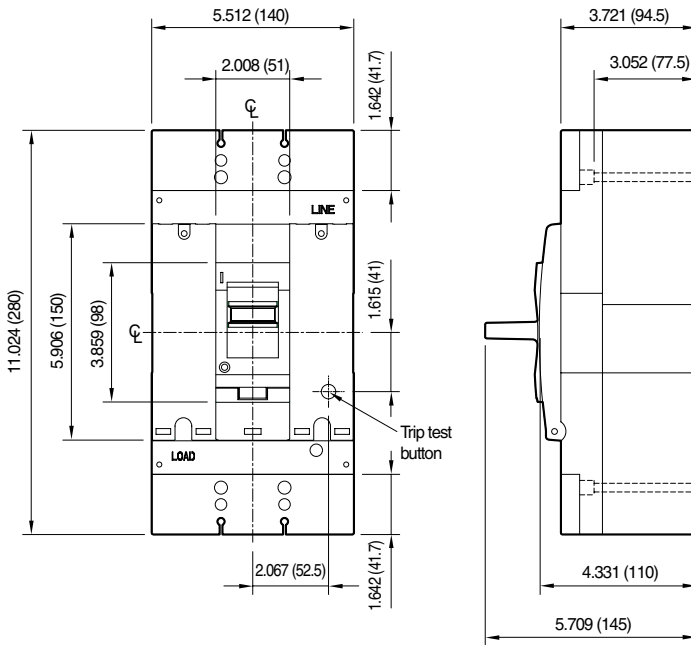

Mounting Bolt Drilling

Panel cut-out

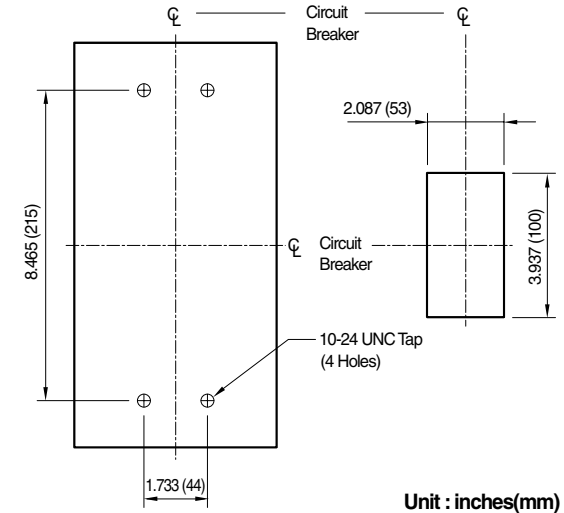

Unit : inches(mm)

ABS/ABH/ABL 602U, 603U, ABN 603U

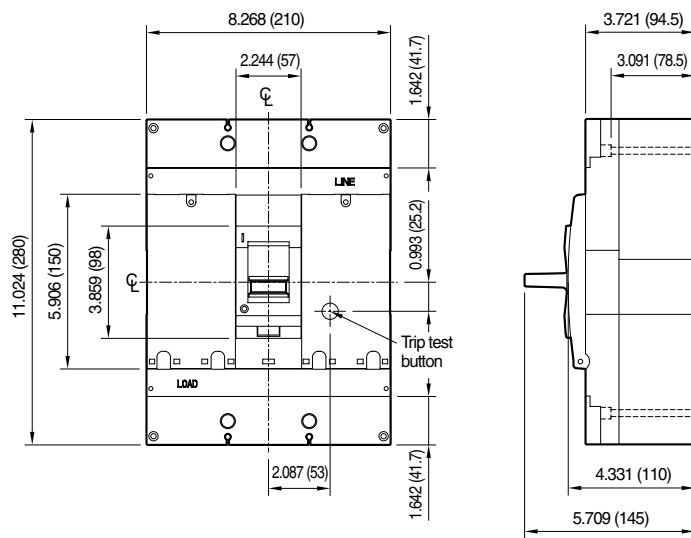

Mounting Bolt Drilling

Panel cut-out

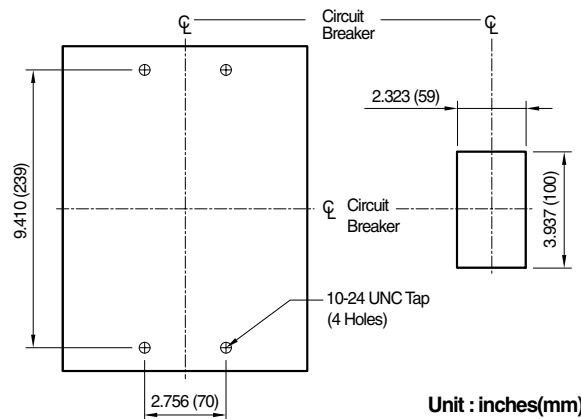

Unit : inches(mm)

UL508 listed MMC / IEC MCCB

Series GB

UL508 Rated Uses

- MMC(Manual Motor Controller)
- Manual Starter / Motor Disconnecter

IEC60947-2 Rated Uses

- Molded Case Circuit Breaker



100AF

GBH103, GBN103



250AF

GBL103,
GBH203, GBL203, GBN203

● UL508 ratings

- 3 pole
- In=16~100amp
- Interrupting capacity .. 30 and 42kA

● IEC60947-2 ratings

- 2, 3 and 4 pole
- In=16~100amp
- Interrupting capacity .. 35 and 50kA

● Trip unit

- Adjustable thermal & fixed magnetic trip
- CE, KEMA certificate according to IEC60947-2
- UL508 listed as a manual motor controller

● UL508 ratings

- 3 pole
- In=16~250amp
- Interrupting capacity .. 30, 42 and 65kA

● IEC60947-2 ratings

- 2, 3 and 4 pole
- In=16~250amp
- Interrupting capacity .. 35, 50 and 85kA

● Trip unit

- Adjustable thermal & adjustable magnetic trip
- CE, KEMA certificate according to IEC60947-2
- UL508 listed as a manual motor controller

Note) GBL103 is the same size with 250AF MMC.

Application according to UL508

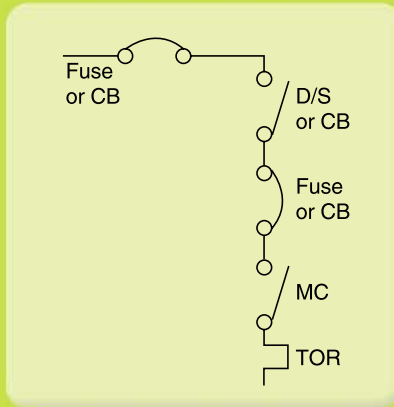

Individual Installation

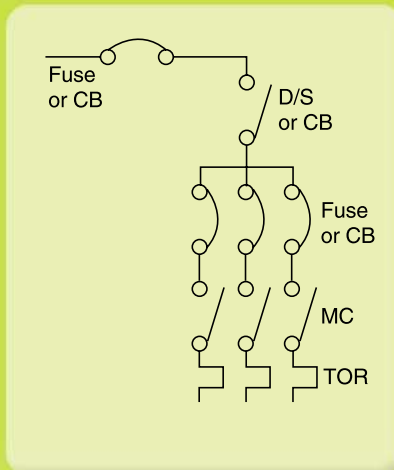
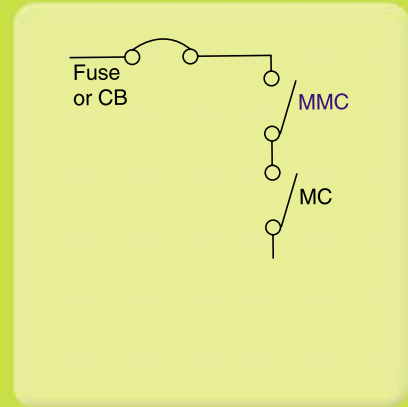

Group Installation

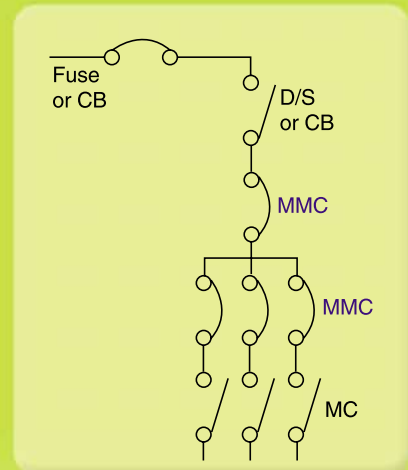

Regend

- **CB** : Circuit Breaker
- **D/S** : Disconnect Switch
- **MC** : Magnetic Contactor
- **TOR** : Thermal Overload Relay
- **MMC** : Manual Motor Controller



Selection Data

Series GB



Manual Motor Controllers

| Frame Size(AF) | | 100AF | | | 250AF | | |
|---|----------|---|--------|----------|--|--------|--------|
| Catalog number | 3-pole | GBN103 | GBH103 | GBL103 | GBN203 | GBH203 | GBL203 |
| Maximum continuous ampere rating at 40°C, In | | 16, 20, 25, 32, 40, 50, 63, 80, 100A Adjustable 0.8/0.9/1.0xIn | | | 125, 160, 200, 250A Adjustable 0.8/0.9/1.0xIn | | |
| UL508 Listed Interrupting ratings (RMS Symmetrical amperes) | 240V AC | | | | | | |
| | 480V AC | 30kA | 42kA | 65kA | 30kA | 42kA | 65kA |
| | 600V AC | | | | | | |
| IEC60947-2 Rated ultimate breaking capacity (RMS Symmetrical amperes) | 240V AC | 50kA | 85kA | 125kA | 50kA | 85kA | 125kA |
| | 415V AC | 35kA | 50kA | 85kA | 35kA | 50kA | 85kA |
| | 600V AC | 18kA | 25kA | 35kA | 18kA | 25kA | 35kA |
| Type of overcurrent device | | Adjustable thermal and fixed magnetic | | | Adjustable thermal and magnetic | | |
| Dimensions Inches(mm) | Width | 3.5(90) | | 4.1(105) | 4.1(105) | | |
| | Height | 5.5(140) | | 6.5(165) | 6.5(165) | | |
| | Depth | 3.4(86) | | 3.4(86) | 3.4(86) | | |
| Shipping weight | Lbs.(kg) | 2.6(1.2) | | 3.7(1.7) | 3.7(1.7) | | |

Catalog Numbering System



| Breaker Type | |
|--------------|------|
| GBN | 30kA |
| GBH | 42kA |
| GBL | 65kA |

| Ampere Frame | |
|--------------|-------|
| 10 | 100AF |
| 20 | 250AF |

| Poles | |
|-------|--------|
| 2 | 2Poles |
| 3 | 3Poles |

| Rated Current | | |
|---------------|-------|------|
| 100AF | 250AF | 125A |
| | | 160A |
| | | 200A |
| | | 250A |
| | | 40A |
| 50A | | |
| 63A | | |
| 80A | | |
| 100A | | |

* by UL508 interrupting rating at 480Vac

Accessories

Auxiliary switch, AX
Alarm switch, AL
Shunt trip unit, SHT
Undervoltage Trip, UVT
- See page 12~13

Rotary handle
Terminal cover
Insulation barrier
Rear connection kits

Interrupting ratings

● According to UL508

- GBN → 30kA
- GBH → 42kA
- GBL → 65kA at AC480V

● According to IEC 60947-2

- GBN → 35kA
- GBH → 50kA
- GBL → 85kA at AC415V

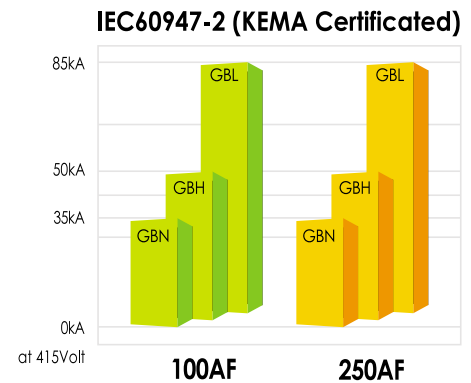
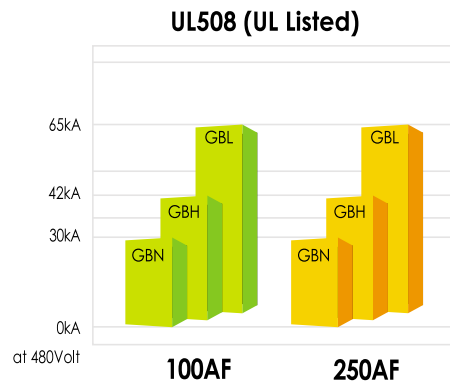

Thermal & Magnetic trip

- TMU type (Thermal-magnetic trip unit)

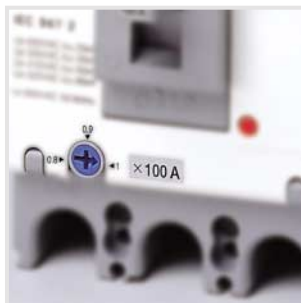

100 Amp. Frame

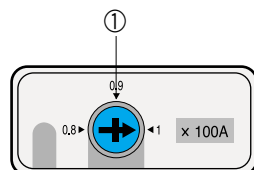

(Adjustable thermal & Fixed magnetic)

- ① Rated current regulating knob, I_r
3 steps : $0.8 / 0.9 / 1.0 \times I_n$

- ② Instantaneous current regulating knob, I_m
 - Fixed instantaneous current type (100AF)
: $10 \times I_n$ (Min. 500A)
 - Adjustable instantaneous current type (250AF)
: $5 / 6 / 7 / 8 / 9 / 10 \times I_n$ (6 steps)



250 Amp. Frame

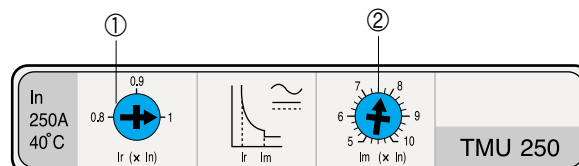

(Adjustable thermal & Adjustable magnetic)

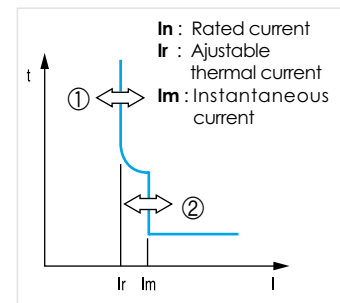

| Frame Size(AF) | Trip unit | 100AF | | | | | | | | 250AF | | | | |
|---------------------|------------------|-------|-------|-------|-------|-------|-------|-----------------|-------|--------|--------------------------------|--------|--------|--------|
| | | TMU16 | TMU20 | TMU25 | TMU32 | TMU40 | TMU50 | TMU63 | TMU80 | TMU100 | TMU125 | TMU160 | TMU200 | TMU250 |
| Ranges of the I_r | $0.8 \times I_n$ | 13 | 16 | 20 | 26 | 32 | 40 | 50 | 64 | 80 | 100 | 128 | 160 | 200 |
| | $0.9 \times I_n$ | 14 | 18 | 23 | 29 | 36 | 45 | 57 | 72 | 90 | 113 | 144 | 180 | 225 |
| | $1.0 \times I_n$ | 16 | 20 | 25 | 32 | 40 | 50 | 63 | 80 | 100 | 125 | 160 | 200 | 250 |
| Ranges of the I_m | | 500A | | | | | | $10 \times I_n$ | | | $5, 6, 7, 8, 9, 10 \times I_n$ | | | |

Specifications

Series GB

| Rated Current [A] | Thermal Release Adjustable Range [A] | Motor Full Load Current [A] | Maximum Horse Power [HP] | | | | | |
|-------------------|--------------------------------------|-----------------------------|--------------------------|------|--------|------|------|------|
| | | | 1Phase | | 3Phase | | | |
| | | | 120V | 240V | 120V | 240V | 460V | 575V |
| 16 | 13 ~ 16 | 3.9 | 1/8 | 1/3 | - | 3/4 | 2 | 3 |
| 20 | 16 ~ 20 | 6.1 | 1/4 | 1/2 | 1/2 | 1.5 | 3 | 5 |
| 25 | 20 ~ 25 | 9.0 | 1/3 | 1 | 1 | 2 | 5 | 7.5 |
| 32 | 26 ~ 32 | 11.0 | 1/2 | 1.5 | 1 | 3 | 7.5 | 10 |
| 40 | 32 ~ 40 | 17.0 | 1 | 3 | 2 | 5 | 10 | 15 |
| 50 | 40 ~ 50 | 22.0 | 1.5 | 3 | 3 | 7.5 | 15 | 20 |
| 63 | 50 ~ 63 | 27.0 | 2 | 3 | 3 | 7.5 | 20 | 25 |
| 80 | 64 ~ 80 | 32.0 | 2 | 5 | 5 | 10 | 20 | 30 |
| 100 | 80 ~ 100 | 41.0 | 3 | 7.5 | 5 | 10 | 30 | 40 |
| 125 | 100 ~ 125 | 52.0 | 3 | 10 | 7.5 | 15 | 40 | 50 |
| 150 | 128 ~ 160 | 62.0 | 5 | 10 | 10 | 20 | 40 | 60 |
| 200 | 160 ~ 200 | 77.0 | 5 | 15 | 10 | 25 | 60 | 75 |
| 250 | 200 ~ 250 | 99.0 | 7.5 | 20 | 15 | 30 | 75 | 100 |

| | | | | | | | | |
|-----|-----------|------|-----|-----|-----|-----|-----|-----|
| 16 | 13 ~ 16 | 3.9 | 1/8 | 1/3 | - | 3/4 | 2 | 3 |
| 20 | 16 ~ 20 | 6.1 | 1/4 | 1/2 | 1/2 | 1.5 | 3 | 5 |
| 25 | 20 ~ 25 | 9.0 | 1/3 | 1 | 1 | 2 | 5 | 7.5 |
| 32 | 26 ~ 32 | 11.0 | 1/2 | 1.5 | 1 | 3 | 7.5 | 10 |
| 40 | 32 ~ 40 | 17.0 | 1 | 3 | 2 | 5 | 10 | 15 |
| 50 | 40 ~ 50 | 22.0 | 1.5 | 3 | 3 | 7.5 | 15 | 20 |
| 63 | 50 ~ 63 | 27.0 | 2 | 3 | 3 | 7.5 | 20 | 25 |
| 80 | 64 ~ 80 | 32.0 | 2 | 5 | 5 | 10 | 20 | 30 |
| 100 | 80 ~ 100 | 41.0 | 3 | 7.5 | 5 | 10 | 30 | 40 |
| 125 | 100 ~ 125 | 52.0 | 3 | 10 | 7.5 | 15 | 40 | 50 |
| 160 | 128 ~ 160 | 62.0 | 5 | 10 | 10 | 20 | 40 | 60 |
| 200 | 160 ~ 200 | 77.0 | 5 | 15 | 10 | 25 | 60 | 75 |
| 250 | 200 ~ 250 | 99.0 | 7.5 | 20 | 15 | 30 | 75 | 100 |

| | | | | | | | | |
|-----|-----------|------|-----|-----|-----|-----|-----|-----|
| 16 | 13 ~ 16 | 3.9 | 1/8 | 1/3 | - | 3/4 | 2 | 3 |
| 20 | 16 ~ 20 | 6.1 | 1/4 | 1/2 | 1/2 | 1.5 | 3 | 5 |
| 25 | 20 ~ 25 | 9.0 | 1/3 | 1 | 1 | 2 | 5 | 7.5 |
| 32 | 26 ~ 32 | 11.0 | 1/2 | 1.5 | 1 | 3 | 7.5 | 10 |
| 40 | 32 ~ 40 | 17.0 | 1 | 3 | 2 | 5 | 10 | 15 |
| 50 | 40 ~ 50 | 22.0 | 1.5 | 3 | 3 | 7.5 | 15 | 20 |
| 63 | 50 ~ 63 | 27.0 | 2 | 3 | 3 | 7.5 | 20 | 25 |
| 80 | 64 ~ 80 | 32.0 | 2 | 5 | 5 | 10 | 20 | 30 |
| 100 | 80 ~ 100 | 41.0 | 3 | 7.5 | 5 | 10 | 30 | 40 |
| 125 | 100 ~ 125 | 52.0 | 3 | 10 | 7.5 | 15 | 40 | 50 |
| 160 | 128 ~ 160 | 62.0 | 5 | 10 | 10 | 20 | 40 | 60 |
| 200 | 160 ~ 200 | 77.0 | 5 | 15 | 10 | 25 | 60 | 75 |
| 250 | 200 ~ 250 | 99.0 | 7.5 | 20 | 15 | 30 | 75 | 100 |

* Fuse : 150A (Class T, Current limiting, Non-time Delay type)
 300A (Class J, Current limiting, Non-time Delay type)
 1000A (Class L, Current limiting, Non-time Delay type)

* Circuit Breaker : 800A(Current limiting type)

| Max. Backup Protection | | | | | | | | | | Catalog No. |
|------------------------|---------------|-----------|---------------|-------------|--------|---------------|-----------|--------|---------------|-------------|
| Single Motor | | | | Group Motor | | | | | | |
| 600V Max. | | 480V Max. | | 600V Max. | | | 480V Max. | | | |
| Fuse [A] | Short Circuit | Fuse [A] | Short Circuit | Fuse [A] | CB [A] | Short Circuit | Fuse [A] | CB [A] | Short Circuit | |
| 150 | 5kA | 150 | 30kA | 1000 | 800 | 5kA | 1000 | 800 | 30kA | GBN103 16A |
| 150 | 5kA | 150 | 30kA | 1000 | 800 | 5kA | 1000 | 800 | 30kA | GBN103 20A |
| 150 | 5kA | 150 | 30kA | 1000 | 800 | 5kA | 1000 | 800 | 30kA | GBN103 25A |
| 150 | 5kA | 150 | 30kA | 1000 | 800 | 5kA | 1000 | 800 | 30kA | GBN103 32A |
| 150 | 5kA | 150 | 30kA | 1000 | 800 | 5kA | 1000 | 800 | 30kA | GBN103 40A |
| 150 | 5kA | 150 | 30kA | 1000 | 800 | 5kA | 1000 | 800 | 30kA | GBN103 50A |
| 150 | 5kA | 150 | 30kA | 1000 | 800 | 5kA | 1000 | 800 | 30kA | GBN103 63A |
| 150 | 5kA | 150 | 30kA | 1000 | 800 | 5kA | 1000 | 800 | 30kA | GBN103 80A |
| 150 | 5kA | 150 | 30kA | 1000 | 800 | 5kA | 1000 | 800 | 30kA | GBN103 100A |
| 300 | 10kA | 300 | 30kA | 1000 | 800 | 10kA | 1000 | 800 | 30kA | GBN203 125A |
| 300 | 10kA | 300 | 30kA | 1000 | 800 | 10kA | 1000 | 800 | 30kA | GBN203 160A |
| 300 | 10kA | 300 | 30kA | 1000 | 800 | 10kA | 1000 | 800 | 30kA | GBN203 200A |
| 300 | 10kA | 300 | 30kA | 1000 | 800 | 10kA | 1000 | 800 | 30kA | GBN203 250A |
| | | | | | | | | | | |
| 150 | 5kA | 150 | 42kA | 1000 | 800 | 5kA | 1000 | 800 | 42kA | GBH103 16A |
| 150 | 5kA | 150 | 42kA | 1000 | 800 | 5kA | 1000 | 800 | 42kA | GBH103 20A |
| 150 | 5kA | 150 | 42kA | 1000 | 800 | 5kA | 1000 | 800 | 42kA | GBH103 25A |
| 150 | 5kA | 150 | 42kA | 1000 | 800 | 5kA | 1000 | 800 | 42kA | GBH103 32A |
| 150 | 5kA | 150 | 42kA | 1000 | 800 | 5kA | 1000 | 800 | 42kA | GBH103 40A |
| 150 | 5kA | 150 | 42kA | 1000 | 800 | 5kA | 1000 | 800 | 42kA | GBH103 50A |
| 150 | 5kA | 150 | 42kA | 1000 | 800 | 5kA | 1000 | 800 | 42kA | GBH103 63A |
| 150 | 5kA | 150 | 42kA | 1000 | 800 | 5kA | 1000 | 800 | 42kA | GBH103 80A |
| 150 | 5kA | 150 | 42kA | 1000 | 800 | 5kA | 1000 | 800 | 42kA | GBH103 100A |
| 300 | 10kA | 300 | 42kA | 1000 | 800 | 10kA | 1000 | 800 | 42kA | GBH203 125A |
| 300 | 10kA | 300 | 42kA | 1000 | 800 | 10kA | 1000 | 800 | 42kA | GBH203 160A |
| 300 | 10kA | 300 | 42kA | 1000 | 800 | 10kA | 1000 | 800 | 42kA | GBH203 200A |
| 300 | 10kA | 300 | 42kA | 1000 | 800 | 10kA | 1000 | 800 | 42kA | GBH203 250A |
| | | | | | | | | | | |
| 150 | 5kA | 150 | 65kA | 1000 | 800 | 5kA | 1000 | 800 | 65kA | GBL103 16A |
| 150 | 5kA | 150 | 65kA | 1000 | 800 | 5kA | 1000 | 800 | 65kA | GBL103 20A |
| 150 | 5kA | 150 | 65kA | 1000 | 800 | 5kA | 1000 | 800 | 65kA | GBL103 25A |
| 150 | 5kA | 150 | 65kA | 1000 | 800 | 5kA | 1000 | 800 | 65kA | GBL103 32A |
| 150 | 5kA | 150 | 65kA | 1000 | 800 | 5kA | 1000 | 800 | 65kA | GBL103 40A |
| 150 | 5kA | 150 | 65kA | 1000 | 800 | 5kA | 1000 | 800 | 65kA | GBL103 50A |
| 150 | 5kA | 150 | 65kA | 1000 | 800 | 5kA | 1000 | 800 | 65kA | GBL103 63A |
| 150 | 5kA | 150 | 65kA | 1000 | 800 | 5kA | 1000 | 800 | 65kA | GBL103 80A |
| 150 | 5kA | 150 | 65kA | 1000 | 800 | 5kA | 1000 | 800 | 65kA | GBL103 100A |
| 300 | 10kA | 300 | 65kA | 1000 | 800 | 10kA | 1000 | 800 | 65kA | GBL203 125A |
| 300 | 10kA | 300 | 65kA | 1000 | 800 | 10kA | 1000 | 800 | 65kA | GBL203 160A |
| 300 | 10kA | 300 | 65kA | 1000 | 800 | 10kA | 1000 | 800 | 65kA | GBL203 200A |
| 300 | 10kA | 300 | 65kA | 1000 | 800 | 10kA | 1000 | 800 | 65kA | GBL203 250A |

* UL File No. : E214031 (UL508/As a Manual Motor Controller)

Characteristic Curves

Series GB

GBN/GBH 103

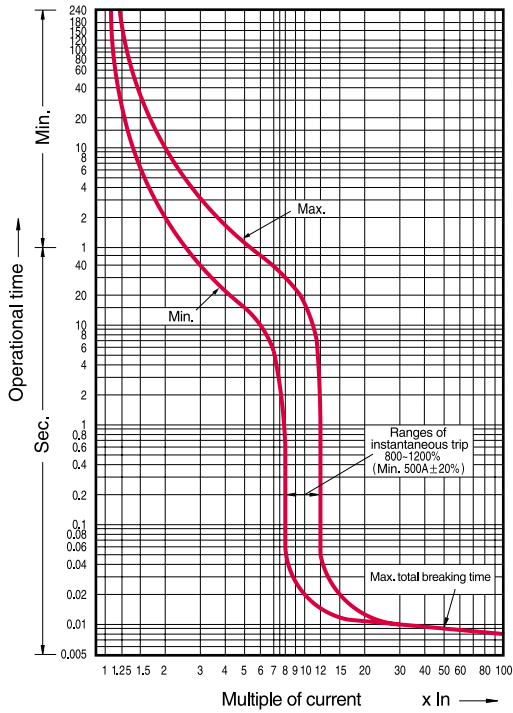

Temperature Compensation Curve

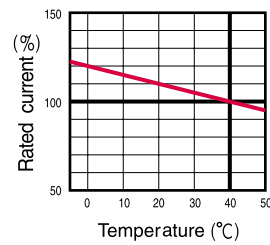

GBL 103, GBN/GBH/GBL 203

16A ~ 100A

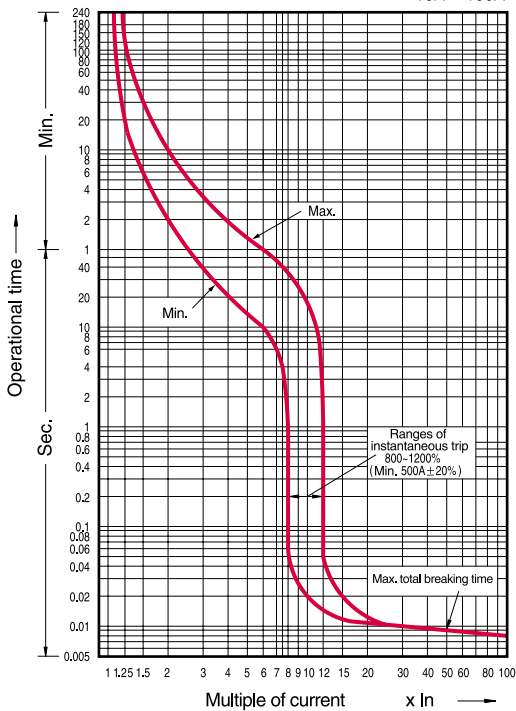

125A ~ 250A

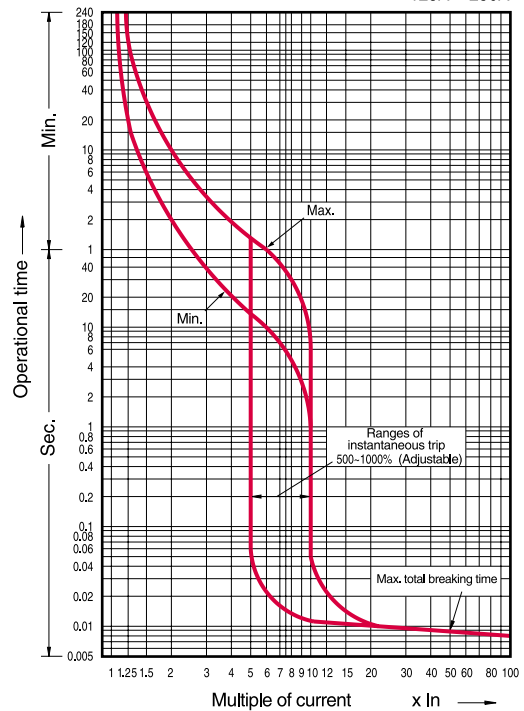

GBN/GBH 103

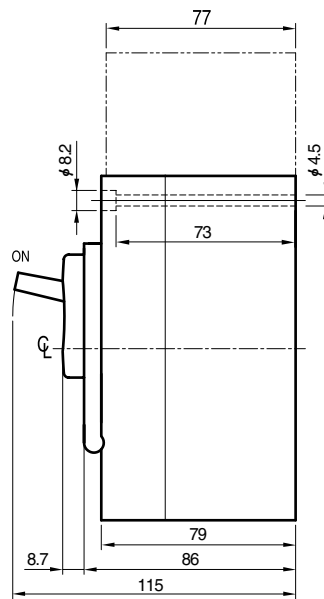
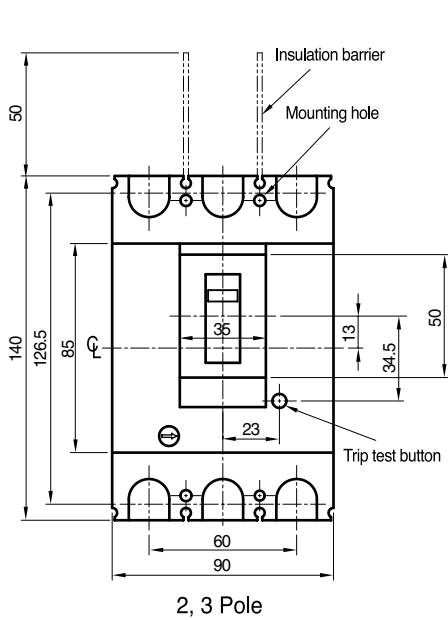

Mounting Bolt Drilling

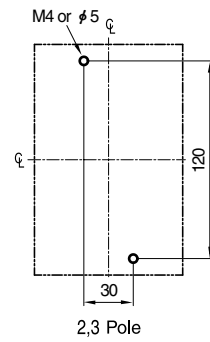

Panel cut-out

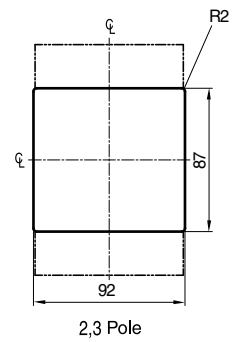

Unit : mm

GBL 103, GBN/GBH/GBL 203

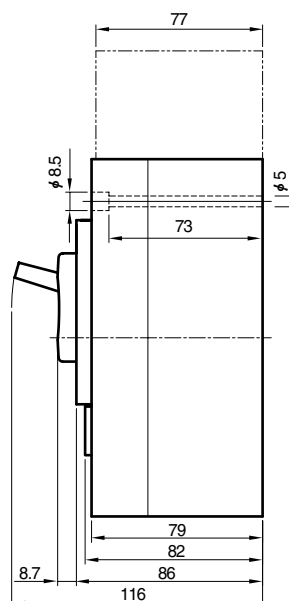
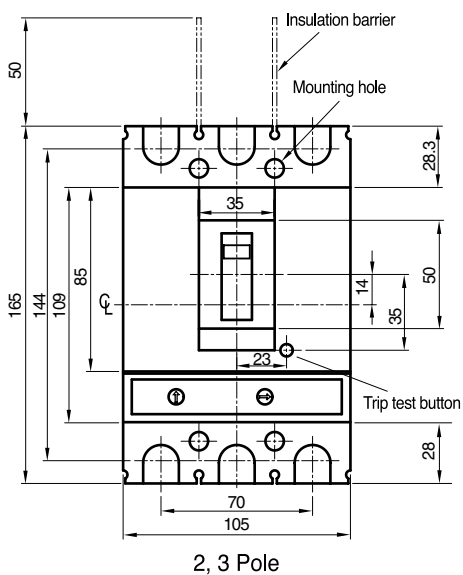

Mounting Bolt Drilling

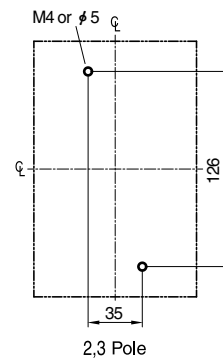

Panel cut-out

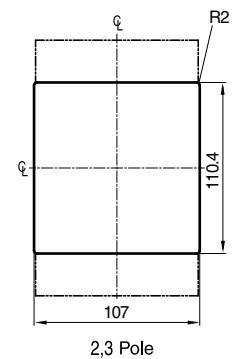

Unit : mm

Leader in Electrics & Automation



Safety Instructions

- For your safety, please read user's manual thoroughly before operating.
- Contact the nearest authorized service facility for examination, repair, or adjustment.
- Please contact a qualified service technician when you need maintenance. Do not disassemble or repair by yourself!
- Any maintenance and inspection shall be performed by the personnel having expertise concerned.

LS Industrial Systems Co., Ltd.

www.lsis.biz

■ HEAD OFFICE

Yonsei Jaedan Severance Bldg. 84-11, 5ga, Namdaemun-ro,
Jung-gu, Seoul 100-753, Korea
Tel. (82-2)2034-4870 Fax. (82-2)2034-4713
<http://www.lsis.biz>

■ CHEONG-JU PLANT

Cheong-Ju Plant #1, Song Jung Dong, Hung Duk Ku,
Cheong Ju, 361-720, Korea
Tel. (82-43)261-6001 Fax. (82-43)261-6410

■ Global Network

- **LS Industrial Systems Tokyo Office Japan**
Address: 16F, Higashi-Kan, Akasaka Twin Towers 17-22, 2-chome,
Akasaka, Minato-ku Tokyo 107-8470, Japan
Tel: 81-3-3582-9128 Fax: 81-3-3582-0065 e-mail: dongjins@lsis.biz
- **LS Industrial Systems Dubai Office UAE**
Address: P.O.Box-114216, API World Tower, 303B, Sheikh Zayed road, Dubai, UAE.
Tel: 971-4-3328289 Fax: 971-4-3329444 e-mail: hwyim@lsis.biz
- **LS-VINA Industrial Systems Co., Ltd Vietnam**
Address: LSIS VINA Congty che tao may dien Viet-Hung Dong Anh Hanoi, Vietnam
Tel: 84-4-882-0222 Fax: 84-4-882-0220 e-mail: srjo@hn.vnn.vn
- **LS Industrial Systems Hanoi Office Vietnam**
Address: Room C21, 5Th Floor, Horison Hotel, 40 Cat Linh , Hanoi, Vietnam
Tel: 84-4-736-6270/1 Fax: 84-4-736-6269
- **Dalian LS Industrial Systems Co., Ltd China**
Address: No. 15 Liaohexi 3 Road, economic and technical
development zone, Dalian, China
Tel: 86-411-8731-8210 Fax: 86-411-8730-7560 e-mail: youngeel@lsis.biz
- **LS Industrial Trading (Shanghai) Co., Ltd China**
Address: Room 1705-1707, 17th Floor Xinda Commercial Building No 322,
Xian Xia Road Shanahai, China
Tel: 86-21-6252-4291 Fax: 86-21-6278-4372 e-mail: hgseo@lsis.biz
- **LS Industrial Systems Beijing Office China**
Address: Room 303, 3F North B/D, EAS 21 XIAO YUN ROAD,
Dong San Huan Bei Road, Chao Yang District, Beijing, China
Tel: 86-10-6462-3259/4 Fax: 86-10-6462-3236 e-mail: sclim@mx.cei.gov.cn
- **LS Industrial Systems Shanghai Office China**
Address: Room 1705-1707, 17th Floor Xinda Commercial Building
No 318, Xian Xia Road Shanahai, China
Tel: 86-21-6278-4370 Fax: 86-21-6278-4301 e-mail: sdhwang@lsis.biz
- **LS Industrial Systems Guangzhou Office China**
Address: Room 303, 3F, Zheng Sheng Building, No 5-6, Tian He
Bei Road, Guangzhou, China
Tel: 86-20-8755-3410 Fax: 86-20-8755-3408
e-mail: lsisgz@public1.guangzhou.gd.cn

Specifications in this catalog are subject to change without notice due to continuous product development and improvement.